TECHNICAL MANUAL

MKR100 REV.5

MKR200 REV.6

DIGITAL KEYSER / MIXER

MKR100 & MKR200

Vortex Communications Ltd

75 The Grove

LONDON W5 5LL, UK

Creation: 09 october 1994

Release : 07 September 2000

SUMMARY

I. INTRODUCTION.	1
II. DESCRIPTION.	1
III. OPERATION.	2
1) Keyer mode.	3
2) Mixer Mode.	4
3) Signals phase.	5
4) Synchronisation.	5
5) Remote control.	5
6) MASK function.	5
7) "CROP" function	6
8) "SOFT" function.	6
9) Type of transition.	6
10) Auxiliary functions.	7
1. Input locking.	7
2. RCK1 adjustment.	7
11) Front panel command.	7
"CUT" key:	7
"AUTOTRANS" key:	7
Transition duration:	7
"FTB" key:	7
12) Preview.	7
13) GPI and Tally :	8
14) RS 232 - RS 422 - RS 485.	9
IV. CONFIGURATION DES MICRO-SWITCHS S4, S3, S2, S1.	10
V. SPECIFICATIONS.	11
GENERAL	11
INPUTS / OUTPUTS	11
KEYING	11
EFFECTS	11
INTERFACES	11
PHYSICAL	11
VI. SCHEMATIC	12

I. INTRODUCTION.

The MKR-100/200 is a 10 bit linear digital keyer/mixer (12 bit internal).

The MKR-100/200 is useful each time that it is necessary to key a text, a drawing or a logo and to remain in the broadcast digital domain.

II. DESCRIPTION.

The MKR-100/200 is housed in a rack 1U / 19 inches.

In front panel.

Seven keys give access to basic functions.

- The "INPUT" key selects an input between two inputs.
- The "CUT" key acts display of the foreground in "on/off" mode.
- The "MIX" key activate a dissolve mode. The key "AUTO " starts the automatic operation.
- The key "HW" activate an horizontal wipe mode. The key "AUTO " starts the automatic operation.
- The key "VW" activate an horizontal wipe mode. The key "AUTO " starts the automatic operation.
- The key "FTB" activate a fade to black.

Others functions are accessible behind the tilting front panel.

Behind the front panel.

- Adjustments of duration of the "MIX", "WIPE", or "FTB" in automatic operation.
- Functions "MASK" and "CROP" and associated adjustments.
- Adjustments of the "SOFT" for wipes and mask.
- System functions such as remote control mode or input locking.

On backplane.

From left to right :

- The network input "M BUS" with loop through for a remote control (RCK2 control desk).
- Foreground digital inputs FG1 - FG2 that correspond to the fill of the key.
- Control digital output for these inputs.
- Remote control subD25 socket (GPI).
- Serial remote control subD9 - RS 232/ RS 422/ RS 485.
- 4 digital outputs.
- Background digital input (BG) and active loop through output.
- Digital reference input and active loop through (MKR200 only).
- Key digital inputs 1 - 2.
- Control digital output for these inputs.
- Power supply input socket.

III. OPERATION.

Important.

The keyer must receive a signal on its BG inputs to operate properly.

Without signal on the BG input keys and indicators don't work.

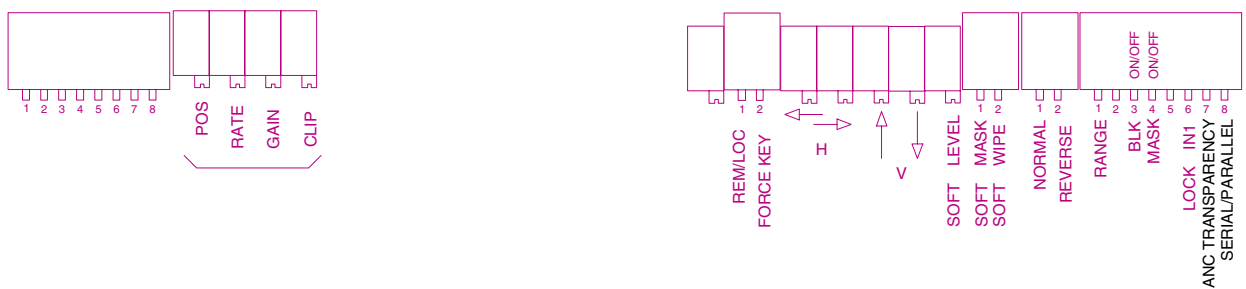

(Fig.1)

The MKR-100/200 can operate in two modes, keyer or mixer.

1) Keyer mode.

Keyer mode is the normal mode. Keyer mode is the delivery default mode.

The keyer mode is active when the commutator 2 of S6 is up in position "Off".

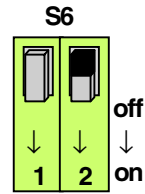

The figure 2 shows a possible keyer wiring in this mode.

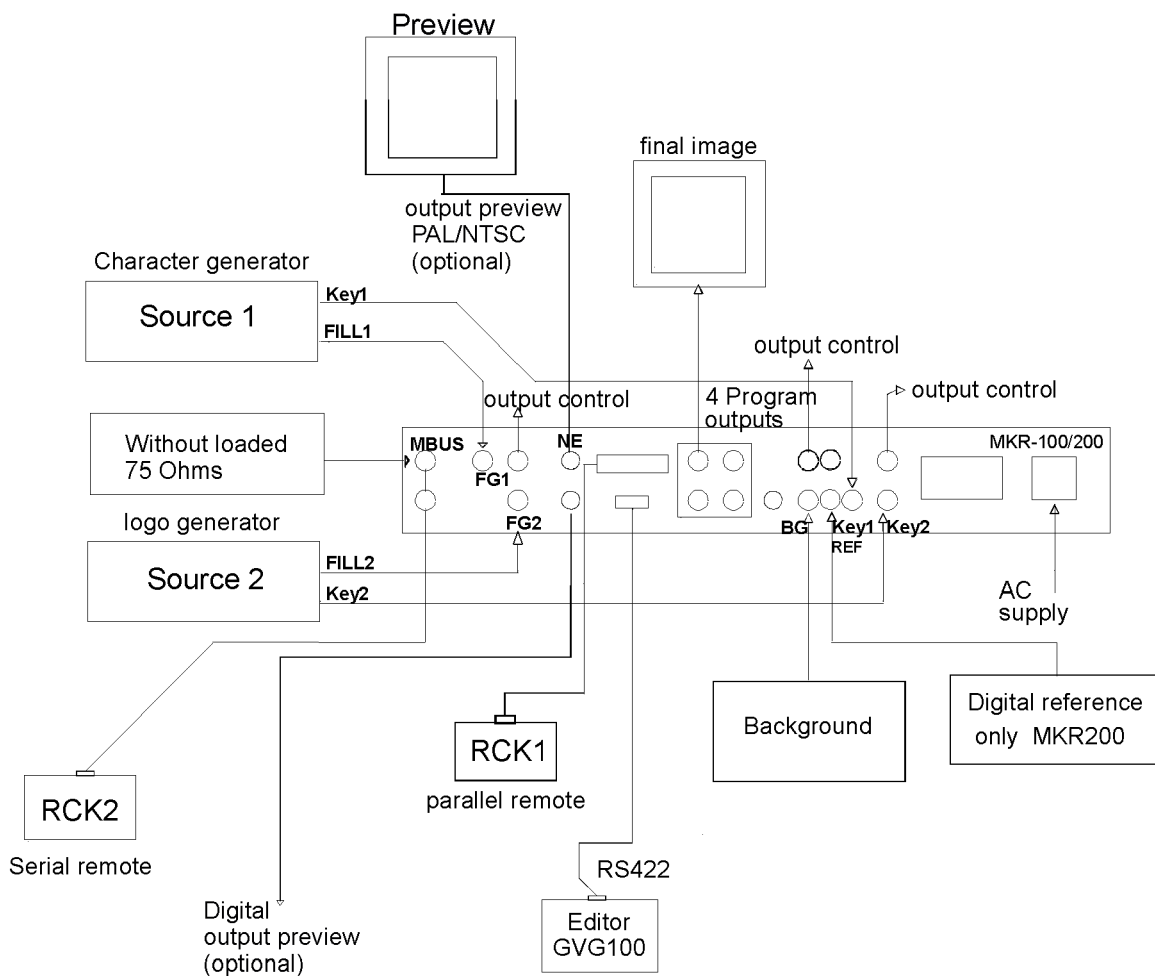

(Fig.2) KEYER MODE

2) Mixer Mode.

In this mode the MKR-100/200 mixes to the two choice sources with the wallpaper "BG".

The mixer mode is active when the commutator 2 of S6 is low in position "On".

The fig.3 shows a possible wiring the MKR-100/200 in mixer mode.

In this mode it is recommended to apply a digital signal on inputs Key 1 and Key 2 to reduce the high frequency radiation.

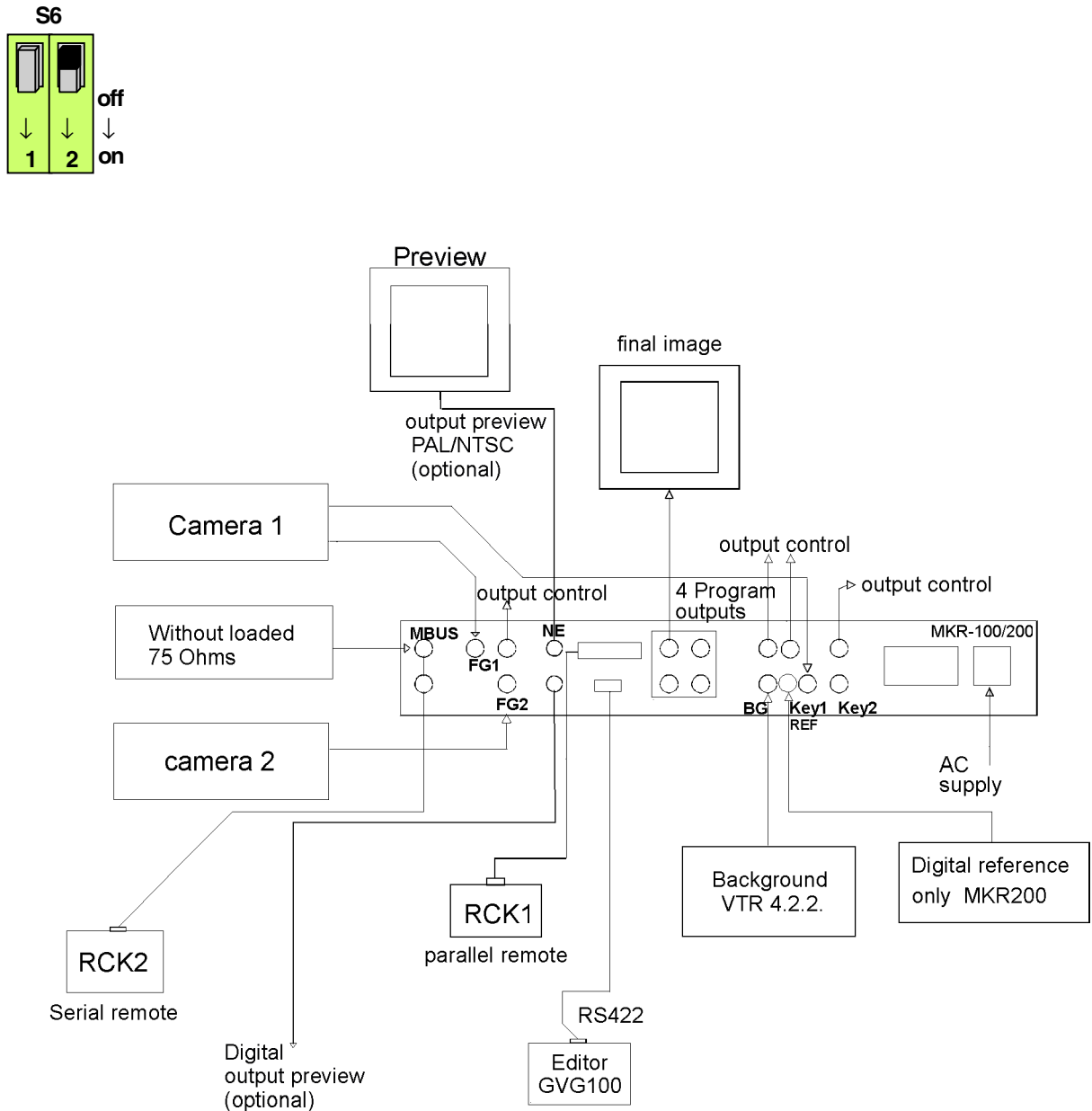

(Fig.3) MIXER MODE

3) Signals phase.

The MKR-100 includes on each input a 1 line auto-phasing.

Thanks to this feature source linking of MKR100 don't need phase adjustment.

The MKR-100 will put sources "Key" and "FG" in phase following the "BG" signal as reference.

The MKR200 will put all sources in phase following the digital reference signal.

4) Synchronisation.

The MKR-100 does not generate synchronisation signals. The synchronisation signal in output will be the one applied on the BG input. The MKR200 insert a new digital sync.

In the absence of signal on this input there is no synchronisation signal in output.

Thanks to this technique one guarantees a complete transparency of the MKR-100 for all auxiliary data as the audio, the E.D.H. or the VITC.

With MKR200 we can blank the ANC (Switch 7 of S5).

5) Remote control.

The MKR-100/200 can operate with local or remote control. In local mode the adjustments are located behind the front panel.

The local mode is active when the commutator 1 of S6 is up in position "Off".

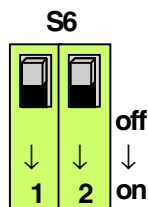

Four adjustments are available in local mode.

"Position" Equivalent to the T-Bar on the remote control desk, adjust wipes position or dissolve.

"Rate" Adjust automatic transition duration or fade to black duration.

"Gain" Adjust key signal gain.

"Clip" Adjust key signal threshold.

NB : Always attempt to work with the minimum of "gain and to compose with the clip".

In remote control mode(RCK1) POS, RATE, GAIN, CLIP function are on the control desk.

The remote mode is active when the commutator 1 of S6 is low in position "On".

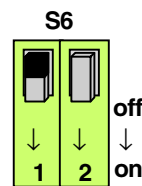

6) MASK function.

The MKR-100 "MASK" generator allows to define a delimited area for keying.

The "MASK" function is active when the commutator 4 of S5 is low in position "On".

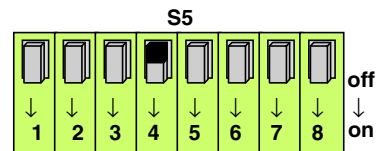

To visualise the MASK push low the commutator 2 of S6.

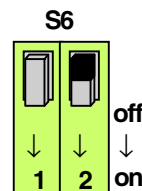

In this case the image is black in regions where the MASK is active.

4 potentiometer RV5 to RV8 set the mask.

Two potentiometers set the horizontal position and two potentiometers set the vertical position.

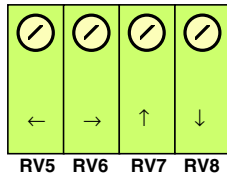

When the MASK is adjusted, don't forget to push up the commutator 2 of S6 in position "Off".

7) "CROP" function

CROP function cleans the image by inserting a black on the image edges in lines and fields.

This function can not be used simultaneously with the "MASK". The "CROP" function is active when the commutator 3 of S5 is low in position "On".

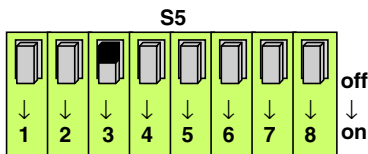

"CROP" adjustment is done by the potentiometers that are used for MASK function - RV5 to RV8.

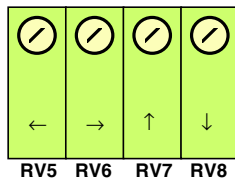

8) "SOFT" function.

SOFT function insert a soft transition - soft edge - in wipes and in mask.

The mask "SOFT" function is active when the commutator 1 of S7 is low in position "On".

The wipe "SOFT" function is active when the commutator 2 of S7 is low in position "On".

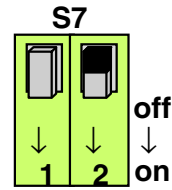

Soft MASK Soft WIPI

RV9 adjust the amount of « softness ».

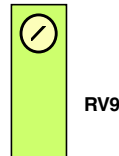

The SOFT function can be active simultaneously on mask and wipes.

9) Type of transition.

The transition type - "normal/reverse" - can be selected by commutator S8.

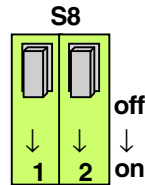

S8	1 NORMAL	2 REVERTS
Normal	on	off
Reverse	off	on
Normal/reverse	off	off
Reverse /Normal	on	on

10) Auxiliary functions.

1. Input locking.

If a single key input is used then the MKR100 can be locked on input 1 by commutator 6 of S5.

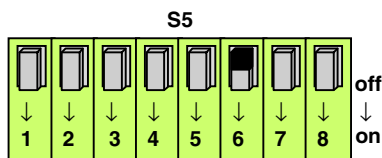

2. RCK1 adjustment.

The range of the T-Bar of RCK1 (remote control) change depending of cable length and T-Bar resistor value. It is necessary to adjust the range before using or after changing RCK1, T-Bar or cable.

The MKR-100/200 include a learning mode for entering T-Bar travel limits.

First push down commutator 1 of S5. Then the "FTB" light indicator blinks.

Push the T-Bar up at full stroke and press the "FTB" button.

Push the T-Bar down at full stroke and press again the "FTB" button.

Then pull up commutator 1 of S5.

The MKR-100/200 has memorized the new limit.

11) Front panel command.

"CUT" key:

The keyed image - foreground - appeared when the key is pressed. This key works in toggle mode.
If the light indicator BG is on then the keyed image is *not* present
If the light indicator FG is on then the keyed image is present.

"AUTOTRANS" key:

The keyed image - foreground - appeared when the key is pressed. The transition mode is selected by "MIX" "HW" or "VW" keys.

If the key "MIX" is lighted then the transition will be a dissolving action.

If the key "HW" is lighted then the transition will be a horizontal wipe.

If the key "VW" is lighted then the transition will be a vertical wipe.

Press keys HW and VW together to select a double wipe - horizontal and vertical.

Transition duration:

In "AUTOTRANS" mode the duration of the transition is adjustable with the potentiometer RATE.

The selected duration is the same for the fade to black.

"FTB" key:

This key start a fade to black.

The light indicator of this key flags a fade to black operation.

12) Preview.

MKR100/200 have two preview outputs.

One in digital another in PAL (or NTSC).

13) GPI and Tally :

The keyer can be controlled by external switches - GPI -.

Available functions are CUT, MIX, HW, VW, AUTO, FTB and IN ½.

These functions are actuated by a intermittent switching to ground.

The MKR-100 returns TALLY informations by open-collector outputs . (maximum current 100mA).

REMOTE		GPI	
BR1	UNCONNECT	BR14	AUTO TALLY
BR2	AUTO GPI	BR15	MIX GPI
BR3	MIX TALLY	BR16	HW GPI
BR4	HW TALLY	BR17	VW GPI
BR5	VW TALLY	BR18	CUT GPI
BR6	CUT TALLY (ON AIR)	BR19	BG TALLY
BR7	FG TALLY	BR20	E ½ GPI
BR8	FTB TALLY	BR21	E ½ TALLY
BR9	FTB GPI	BR22	GND
BR10	GND	BR23	GND
BR11	UNCONNECT	BR24	+5V
BR12	+5V	BR25	UNCONNECT
BR13	UNCONNECT		

SUB.D 25 PIN-OUT

14) RS 232 - RS 422 - RS 485.

The MKR-100/200 includes an output port - female 9 pins sub.D - it can be assigned internally by jumpers in RS232, RS422 or RS485.

Selectable rate until 19200 bauds.

Number of bit 5 to 8.

Number of stop bit 1 to 2.

Even, odd or none parity.

RS 232	
BR1	GND
BR2	RX
BR3	TX
BR4	DTR
BR5	GND
BR6	DSR
BR7	RTS
BR8	CTS
BR9	GND

RS 422 SMPTE 207M -1992	
BR1	GND
BR2	TRANSMIS. A
BR3	RECEIVE B
BR4	RECEIVE COMMON
BR5	SPARE
BR6	TRANSMIS. COMMON
BR7	TRANSMIS. B
BR8	RECEIVE A
BR9	FRAME GROUND

RS 485	
BR1	GND
BR2	TRANSMIS./RECEIVE A
BR3	RECEIVE B
BR4	RECEIVE COMMON
BR5	SPARE
BR6	TRANSMIS. COMMON
BR7	TRANSMIS. RECEIVE B
BR8	RECEIVE A
BR9	FRAME GROUND

IV. CONFIGURATION DES MICRO-SWITCHS S4, S3, S2, S1.

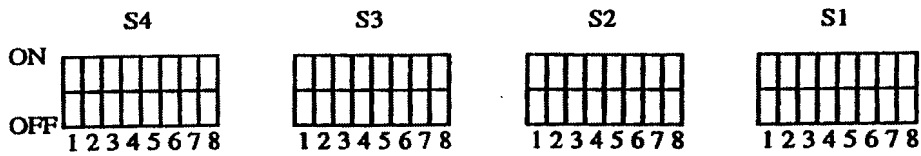

S1 : Serial link address for MBUS

S2 : Protocole Address for GVG100

(BUTTONS DRAWN IN BLACK)

S3 : Serial port description :

- switches 1, 2 number of bits :



1 2
5 Bits



1 2
6 Bits



1 2
7 Bits



1 2
8 Bits

- switch 3 stop bit :



3
1 stop bit



3
2 stop bit

- switches 4, 5 parity :



4 5
none



4 5
odd



4 5
spare



4 5
even

- switches 6, 7, and 8 Baud rate :



6 7 8
300



6 7 8
2400



6 7 8
4800



6 7 8
9600



6 7 8
19200



6 7 8
25600



6 7 8
38400



6 7 8
76800

P16 : 1-2 = RS485 2-3 = RS422

P17 : P18 : 1-1 = RS232C 2-2 = RS485 3-3 = RS422

P19 : 2-3 P20 = ON P22 = ON

P21 : ON- Battery used OFF = Battery not used

P30/1 to P9/1 P30/2 to P9/2 P30/3 to P9/3...P30/10 to P9/10 = RS232C

P30/1 to P12/1 P30/2 to P12/2 P30/3 to P12/3... P30/10 to P12/10 = RS422

V. SPECIFICATIONS.

GENERAL

- Down stream keyer (DSK)
- Multilayer keying
- Linear keying and some mixing functions.
- Fully digital 12 bit internal processing.
- One rack 19" - 1 Unit.
- Plug in board.
- Push button controls on the front side, or remote.
- Parameters assignment and configuration with switches and potentiometers located behind the front panel.

INPUTS / OUTPUTS

- Inputs / outputs serial 4:2:2:, 10 bits
- 625 / 525 lines.
- 2 sources can be selected on each input, and monitoring output.
- Distributing amplifier 4 outputs.
- Sync reference from the background signal MKR100.
- External sync reference MKR200.
- 1 H/64 μ s auto-phasing on each input and manual retiming.
- Fully transparent on the blanking areas H and V. No alteration of the auxiliary data carried by the background signal.
- Accurate cleaning of the edge with the H and V blanking on the final output.
- Delay 2,5 μ S
- Input output impedance 75 Ω .
- Cable equalization 150 m (BELDEN 8281)

KEYING

- Key level and clip accurate adjustment.
- Linear keying multiplicative.
- Mix mode.
- Mask effects for limitation of the keying are with adjustable soft edge.

EFFECTS

- H and V wipes.
- Adjustable soft wipe edge.
- Key or mix with cut or mix mode.
- Separate fade to black.
- Automatic fades or wipes with adjustable duration.

INTERFACES

- RS232 / RS422 / RS485
- GPI inputs.
- Tally.
- RCK1 GPI remote control.
- RCK2 remote control.
- GVG-100 protocol on request.

PHYSICAL

- 1U - 19" rack mount
- Overall dimensions : 44,5 x 483 x 425mm
- Weight : 5kg
- Power supply : 220/110V \pm 10% 50/60Hz
- Consumption 50VA max.
- Redundant power supply (option).

VI. SCHEMATIC

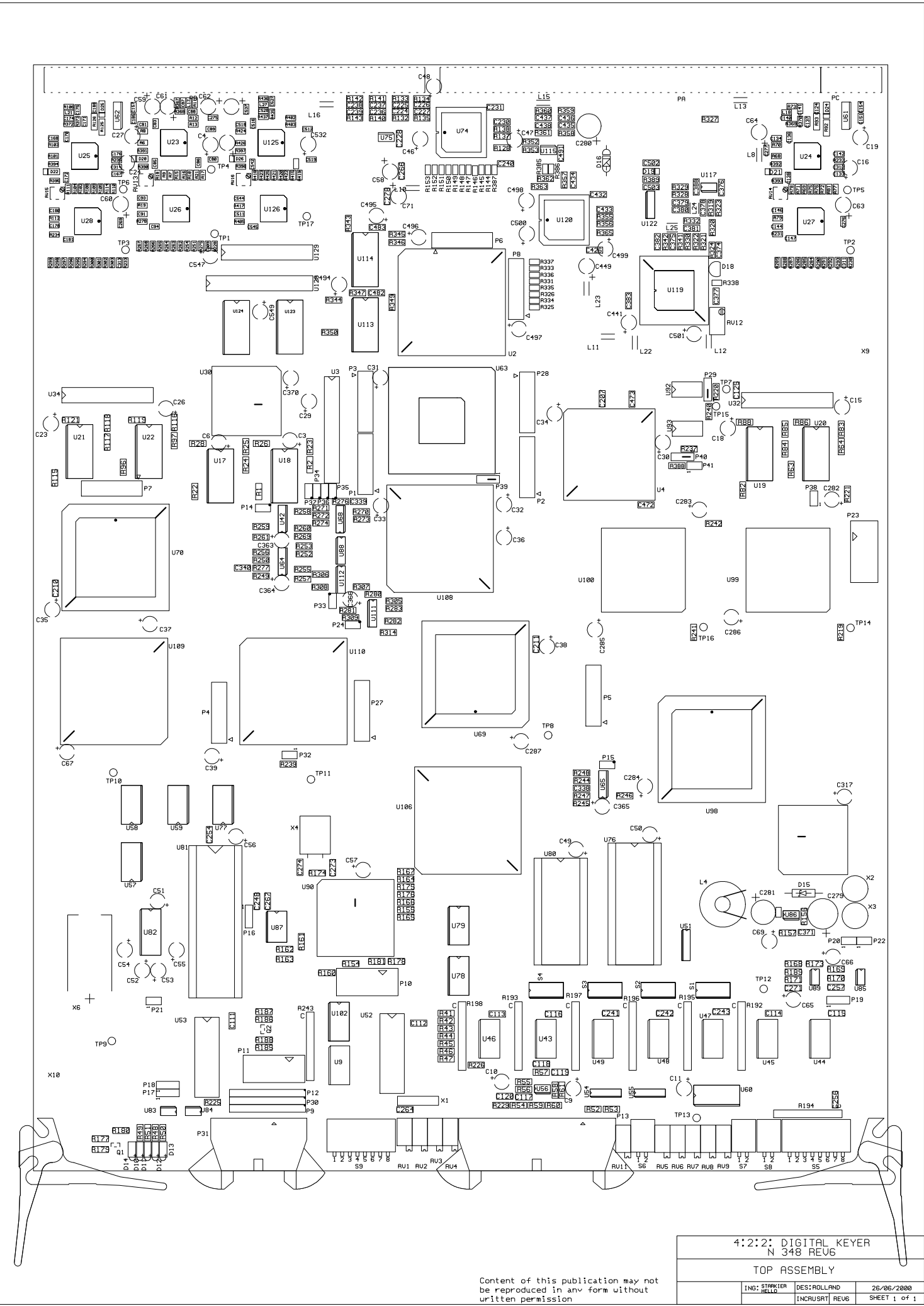

4:2:2: DIGITAL KEYS
N 348 REV6

TOP ASSEMBLY

Content of this publication may not be reproduced in any form without written permission

ING: STARKER BELL	DES: ROLLAND	26/26/2000
	INCRSRT: REV6	SHEET 1 of 1

